

 **Husqvarna**

**VIKING**

# Parts list

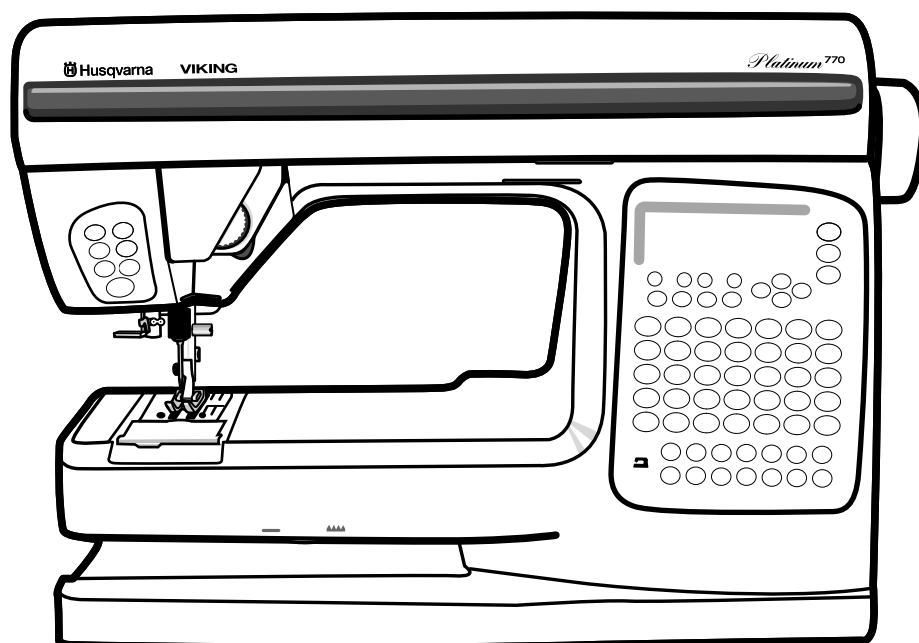

# PLATINUM 770

Part no	Description	Page	Part no	Description	Page
411 72 10-01	Washer	C	412 36 84-01	Cog belt	G
411 78 10-03	Bulb 4 V	E	412 36 87-01	Pin	G
411 96 68-01	Screw	A,E	412 37 11-01	Thread reel disc 20 mm	A
411 96 68-03	Screw	A,F	412 37 11-02	Thread reel disc 40 mm	A
411 96 68-04	Screw	E	412 37 82-01	Nut	C
411 96 68-10	Screw	B	412 39 09-25	Plastic bag with access. Platinum 770	L
411 96 68-12	Screw	B	412 39 12-01	Spring presserfoot lifter	E
411 96 68-21	Screw	E	412 39 47-01	Washer	D
411 96 68-25	Screw	F	412 40 97-01	Screw	F
411 96 71-07	Screw	B	412 41 12-01	Ankel	F
411 96 81-01	Screw	D	412 42 37-01	Thread knife	A,D
412 00 13-01	Washer	D	412 44 40-02	Hook	D
412 05 60-01	Screw M5*14	B	412 44 44-01	Cog wheel	D
412 05 60-04	Screw M3*6	I	412 45 23-01	Thread knife	A
412 05 60-06	Screw M4*12	B,G,H,I	412 45 24-01	Holder, thread knife	A
412 05 60-07	Screw M4*16	J	412 45 55-01	Spring	J
412 05 60-11	Screw M3*5	C,D	412 45 56-01	Adjusting sleeve	J
412 14 30-05	Fuse 6.3 A/250 V	B	412 45 57-01	Bracket and lever	J
412 14 30-06	Fuse 2 A/250 V	B	412 45 59-01	Plugg	J
412 14 32-03	Fuse 3.5 A/250 V (USA)	B	412 45 91-01	Hook cover, window	D
412 14 32-05	Fuse 2 A/250 V (USA)	B	412 46 44-01	Adjusting screw, thread tension	D
412 15 78-01	Cord device, stand.	K	412 46 45-01	Screw, thread tension	D
412 15 79-03	Cord device, USA, Can.	K	412 47 16-01	Thread tension compl.	D
412 15 80-02	Cord device, England	K	412 47 73-01	Bobbin case holder	D
412 15 81-01	Cord device, Australia	K	412 48 09-02	Protector, take up	A
412 15 98-01	Spring	K	412 49 25-02	Foot control compl.	K
412 18 45-01	Foot	K	412 49 44-01	Control unit	K
412 21 14-01	Screw	E	412 49 49-01	Distance sleeve	B
412 21 14-03	Screw, torx M3*8	F	412 50 06-01	Bearing	E
412 21 14-06	Screw	F	412 50 08-01	Gear segment	F
412 21 14-11	Screw, Torx M4*8	D	412 50 09-01	Spring	F
412 21 14-14	Screw, torx M4*16	B	412 50 10-01	Spring	F
412 22 98-01	Locking nut	I	412 50 11-01	Link	F
412 28 19-02	Screw	C,E	412 50 15-01	Bearing	F
412 28 54-02	Presser bar	F	412 50 19-01	Back holder - Needle threader	F
412 28 75-01	Base plate	B	412 50 20-01	Front holder - Needle threader	F
412 28 79-01	Screw	D	412 50 21-01	Needle threader	F
412 28 79-02	Screw	J	412 50 22-01	Setting plate	F
412 30 06-01	Driver	G	412 50 23-02	Eccentric / needle adj,	F
412 30 07-01	Spring	G	412 50 24-01	Cross head compl.	F
412 30 08-01	Pulley	G	412 50 27-01	Calibration stop	E
412 30 09-02	Hand wheel	G	412 50 46-01	Wedge	F
412 30 16-01	Link	J	412 50 47-01	Clamp ring	F
412 30 21-01	Locking washer	J	412 50 48-01	Clamp ring	E
412 30 30-01	Guide arm	E	412 50 52-01	Plate	F
412 30 50-01	Foot	B	412 50 55-01	Frame - lower	F
412 30 55-01	Rubber ring	B	412 50 72-01	Spring	I
412 30 66-01	Shuttle shaft	D	412 51 36-02	Feed dog cpl,	C
412 30 74-01	Damper	D	412 51 37-01	Guide cpl with carrier	C
412 30 97-01	Presser bar lifter	E	412 51 43-01	Guide blocks	C
412 31 44-01	Cable standard	K	412 51 44-01	Feed carriage	C
412 31 44-02	Cable USA, Can, Japan	K	412 51 49-01	Spring	C
412 31 69-01	Spring	F	412 51 53-01	Spring	C
412 31 79-01	Clutch	G	412 51 54-01	Feed Lift	C
412 31 81-01	Clamp, lower shaft	H	412 51 55-01	Spring	C
412 31 84-01	Bushing, feed dog	C	412 51 56-01	Stop ring	C
412 32 27-05	Bobbin winding	B	412 51 63-01	Worm gear	H
412 32 33-02	Sealing washer	A	412 51 68-02	Lower shaft compl.	H
412 32 34-09	Step motor, feeding	I	412 51 69-01	Eccentric feed	H
412 32 34-10	Step motor, sewing head	E	412 51 70-01	Distance	H
412 32 47-01	Lever thread tension	J	412 52 09-01	Thread holder	A
412 32 49-01	Screw thread tension	J	412 52 10-01	Reel pin	A
412 32 50-01	Spring holder	J	412 52 14-01	Spring	A
412 32 67-45	PC-board transformer	B	412 52 97-02	Protector, accessorie box	L
412 32 71-45	Transformer 220-240 V	B	412 53 30-01	Stitch plate	D
412 32 71-47	Transformer 120 V	B	412 53 34-01	Reel pin holder	A
412 32 71-48	Transformer 100 V	B	412 53 37-01	Knob feed dog lowering	A
412 32 84-01	Clamp	G,H	412 54 02-01	Feeding step motor cpl,	I
412 33 62-01	Cog Gear	E	412 54 06-01	Calibration stop	I
412 33 93-01	Attachment, motor	B	412 54 07-01	Damper	I
412 33 94-01	Muffler, motor	B	412 54 08-01	Cog wheel	I
412 33 97-02	Motor 24 V	B	412 54 10-01	Shaft	I
412 34 26-03	Spring	B	412 54 97-01	Tap thread guard	A
412 34 47-01	Holder	B	412 54 98-01	Washer	A
412 34 50-01	Eccentric	B	412 55 01-01	Bobbin case compl.	D
412 34 54-01	Cog belt	G	412 55 43-02	Bobbin wounding cover cpl,	A
412 34 60-01	Stop ring	H	412 55 79-01	Bobbin wounding excenter	A
412 34 81-01	Spring	I	412 55 80-01	Thread support	A
412 34 82-01	Setting screw	I	412 55 81-01	Washer	A
412 34 85-01	Joint cross	I	412 55 84-01	Damper-upper shaft	G
412 34 88-01	Fastener, spring	I	412 56 15-45	Plastic bobbins (10-pac)	D,L
412 34 96-01	Cablage motor	B	412 56 31-01	Thread support	A
412 34 97-01	Cable for PC-board	B	412 56 85-01	Dust cover	D
412 35 26-01	Washer	H	412 56 86-01	Adjusting washer	D
412 35 31-01	Thread tension set	J, L	412 57 01-01	Sleeve, lamp	L
412 35 33-02	Driving wheel compl.	B	412 58 17-02	Needle bar compl.	F
412 35 42-01	Pulley	H	412 58 18-01	Needle clamp	F
412 35 62-01	Pin	B	412 58 19-01	Thread guide	F
412 35 64-01	Holder	B	412 60 01-01	Needle bar frame	F
412 36 14-01	Opener, stitch plate	L	412 60 03-01	Thread take up	E
412 36 83-04	Arm shaft	G			

Part no	Description	Page
---------	-------------	------

412 68 24-01	Front Cover Empty	A
412 68 25-01	Lid cover	A
412 68 29-01	Support	D
412 68 31-01	Back cover	A
412 68 32-01	Free arm cover	A
412 68 34-01	Handle	A
412 68 36-01	Base plate	B
412 68 37-01	Hard cover	L
412 68 38-01	Accessory box complete	L
412 68 47-01	Presser bar guide cpl,	F
412 68 48-01	Frame	E
412 68 50-01	Regulating dial	E
412 68 51-01	Spring-Presser bar	F
412 68 63-01	Feed dog compl,	C
412 68 64-01	Feed dog	C

412 68 72-01	Shaft-feed dog lowering	A
412 68 76-01	Aluminium foil	G
412 69 31-01	Window / Front cover	A
412 69 36-01	Spring	E
412 69 37-01	Screen	A
412 69 39-45	PC-board Platinum 770	B
412 69 51-01	Thread guide	A
412 69 65-01	Connector sensor with cable	E, F
412 69 87-01	Adjusting arm	B
412 69 92-02	Adjustment dial	J
412 69 94-01	Thread tension device	J
412 69 97-01	Screen - Stoprigh func	H
412 70 08-01	Thread guide	A
412 70 21-01	Plug, card hole	A
412 70 80-01	Accessory box	L
412 70 81-01	Cover accessory box	L
412 70 82-01	Locking snap, Acc box	L
412 70 83-01	Inside tray, Acc box	L

412 70 98-01	Spring, Accessorie box	L
412 72 20-01	Main foil key board	A
412 72 23-01	Foil key board sewing head	A
412 73 23-01	Screw	F
412 74 61-01	Foot pedal-empt	K
412 75 31-01	Hook cover	D
412 76 85-01	Sewing head cpl.	E
412 76 89-01	Front cover cpl.	A

721 41 69-70	Pin	I
721 41 87-70	Pin	GH
721 42 10-10	Pin	H
725 52 20-05	Screw M3*6	I
725 52 28-05	Screw	F
728 52 17-05	Screw M3*3	E,I
728 52 19-05	Stop screw	F
728 52 22-05	Screw	F
728 52 83-05	Srew	C
728 52 85-05	Screw M4*6	F
728 52 87-05	Screw M4*8	D
728 53 20-05	Screw M5*5	G
728 73 20-01	Screw	G
728 73 64-05	Screw 6*10 mm	B

728 82 83-05	Screw M4*4	GH
735 11 25-41	Washer	F
735 21 36-01	Locking washer	B
735 31 08-20	C-washer	D
735 58 05-10	Locking washer	E
735 58 23-00	Locking washer	A
735 58 35-00	Locking washer	A
735 58 55-00	Washer	G
735 61 18-40	C-washer	F
735 61 24-40	Compression ring 3mm	E,J
735 61 36-40	C-washer	E
735 61 53-40	Compression ring 6mm	E

**ACCESSORIES**

401 53 99-01	Buttonhole knife	L
401 55 55-01	Brush	L
411 17 32-01	Clearance plate	L
412 08 38-47	Marking pen, neutral	L
412 56 15-45	Bobbins (10)	L
412 36 14-01	Stitch plate opener	L
412 38 15-01	Screw driver	L
412 62 09-01	Grip aid	L

**PRESSERFEET**

411 73 95-01	Edge guide G	L
411 85 30-01	Presser foot H	L
412 00 16 -01	Presser foot decorative stitches	L
412 03 73-01	Presser foot A	L
412 37 08-01	Quilting foot P	L
412 38 01-01	Presser foot B	L
412 38 02-01	Buttonhole foot C	L
412 38 04-01	Presser foot D	L
412 38 05-01	Zipper foot E	L
412 38 06-01	Presser foot J	L
412 40 80-01	Button hole sensor, comp.	L

Part no	Description	Page
---------	-------------	------

Users Guide		
412 73 38-01	Users Guide Swe	L
412 73 38-06	Users Guide Dan	L
412 73 38-10	Users Guide Jap	L
412 73 38-11	Users Guide Fin	L
412 73 38-21	Users Guide Nor	L
412 73 38-26	Users Guide Eng	L
412 73 38-31	Users Guide Fra	L
412 73 38-36	Users Guide Holl	L
412 73 38-41	Users Guide Ita	L
412 73 38-51	Users Guide Germ	L
412 73 38-56	Users Guide Russ	L
412 73 38-82	Users Guide Pol	L
412 73 38-90	Users Guide Cz	L

**Owners Handbook**

412 73 39-01	Owners Handbook Swe	L
412 73 39-06	Owners Handbook Dan	L
412 73 39-10	Owners Handbook Jap	L
412 73 39-11	Owners Handbook Fin	L
412 73 39-21	Owners Handbook Nor	L
412 73 39-26	Owners Handbook Eng	L
412 73 39-31	Owners Handbook Fra	L
412 73 39-36	Owners Handbook Holl	L
412 73 39-41	Owners Handbook Ita	L
412 73 39-51	Owners Handbook Germ	L
412 73 39-56	Owners Handbook Russ	L
412 73 39-82	Owners Handbook Pol	L
412 73 39-90	Owners Handbook Cz	L

A

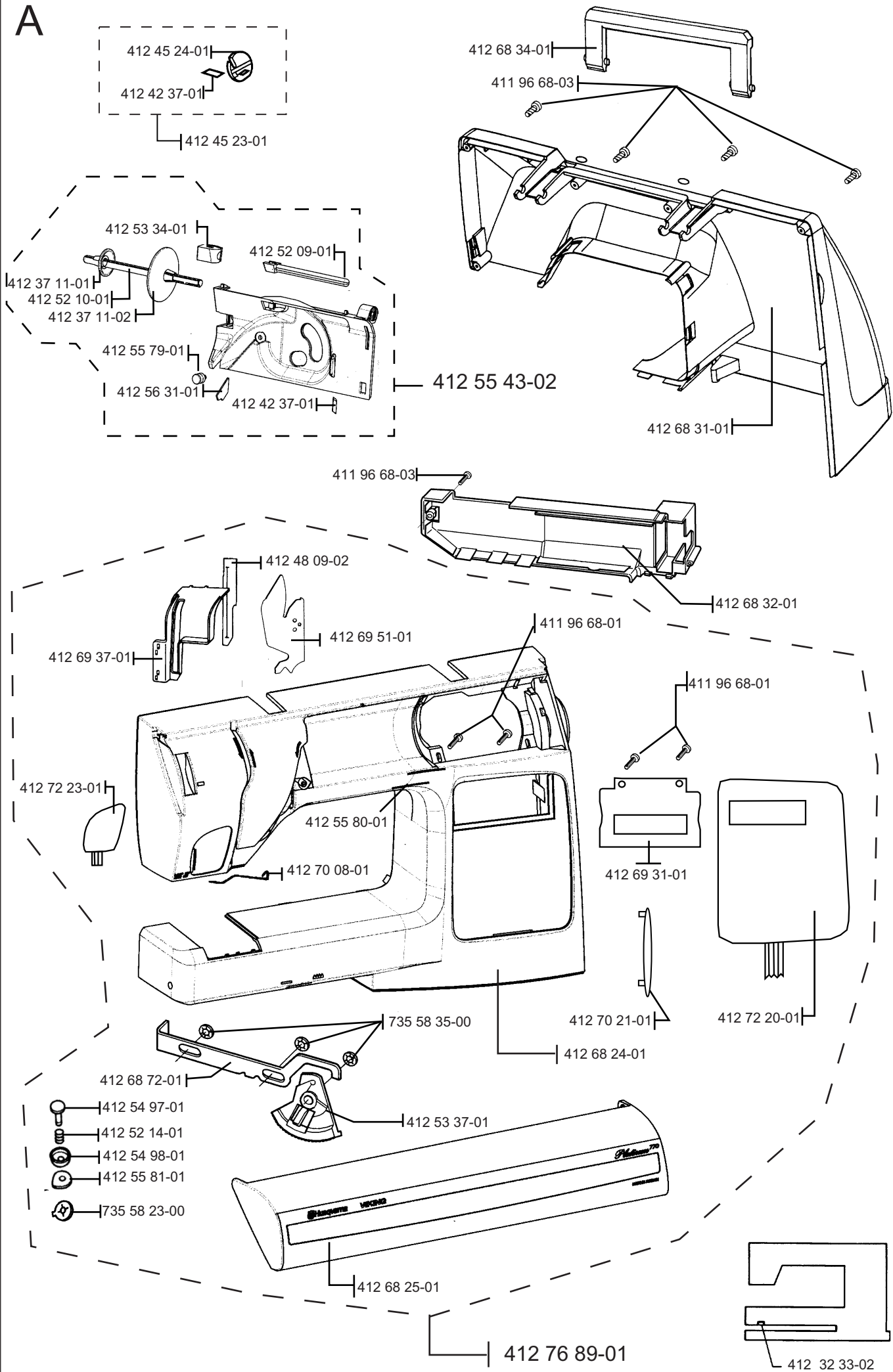

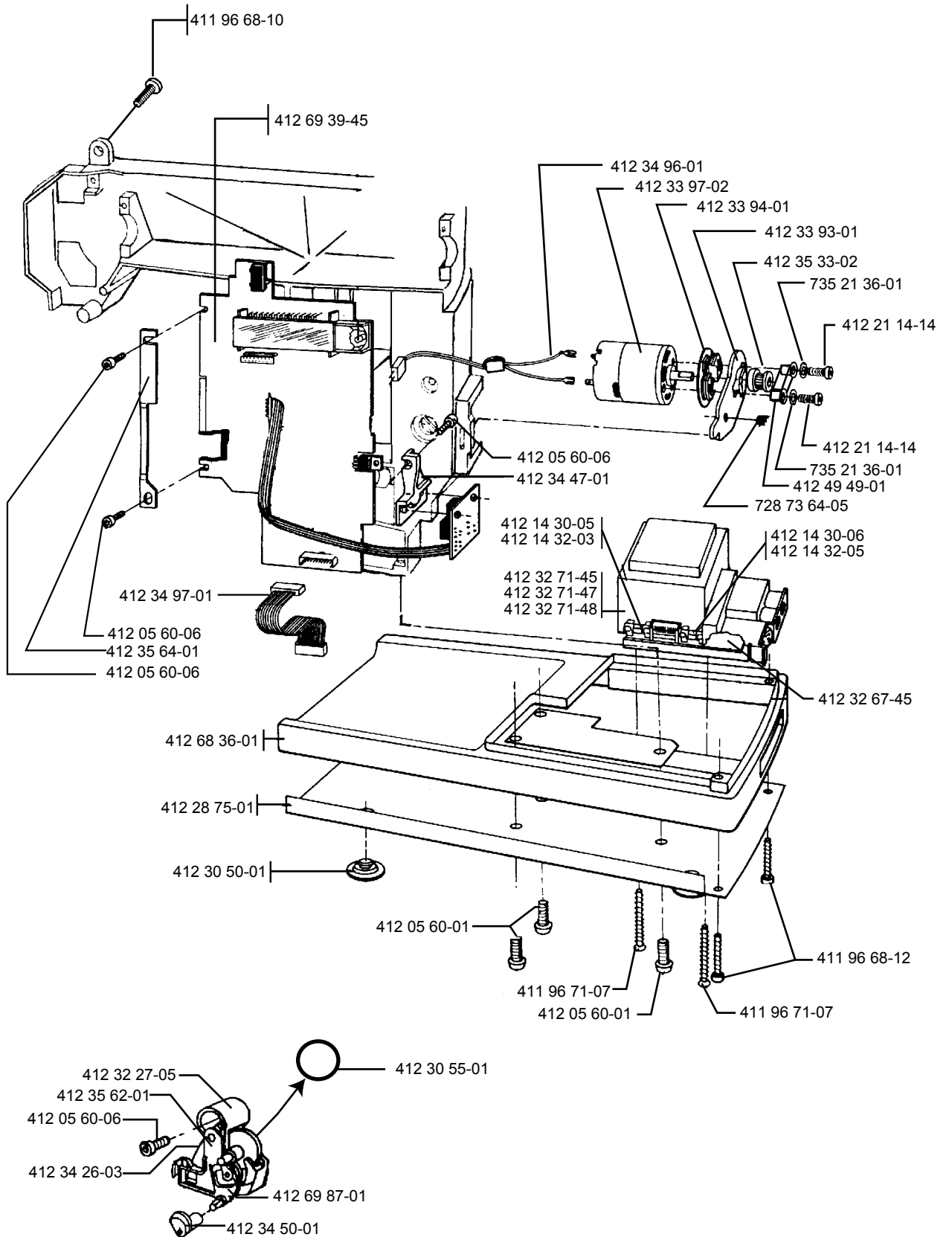

C

412 51 36-02

412 68 63-01

412 51 37-01

412 31 84-01

412 37 82-01

412 51 43-01

412 51 44-01

412 51 55-01

412 51 54-01

411 72 10-01

412 51 56-01

411 72 10-01

728 52 83-05

412 51 49-01

412 05 60-11

412 28 19-02

412 28 19-02

412 51 53-01

411 72 10-01

728 52 83-05

D

412 53 30-01

412 45 91-01

412 47 73-01

412 42 37-01

412 28 79-01

411 96 81-01

412 28 79-01

412 75 31-01

412 30 74-01

412 21 14-11

412 05 60-11

412 21 14-11

412 68 29-01

412 55 01-01

412 56 15-45

412 47 16-01

412 46 44-01

412 46 45-01

735 31 08-20

412 44 40-02

412 39 47-01

412 00 13-01

412 44 44-01

412 56 85-01

412 39 47-01

412 56 86-01

412 30 66-01

728 52 87-05

412 76 85-01

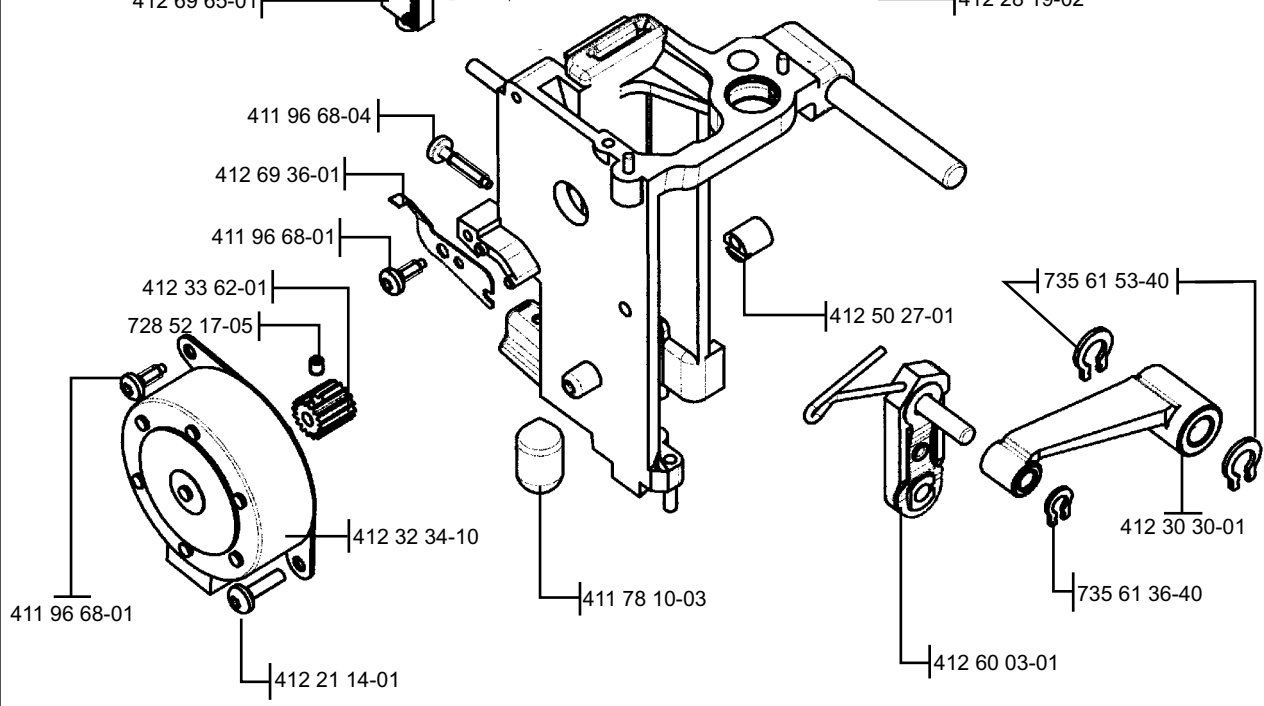
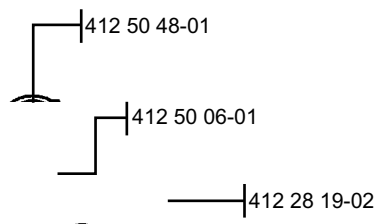
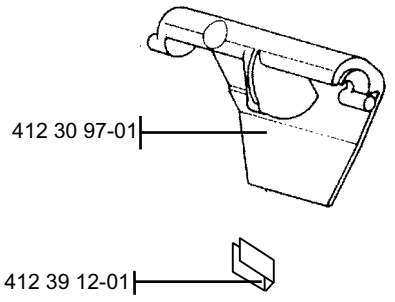
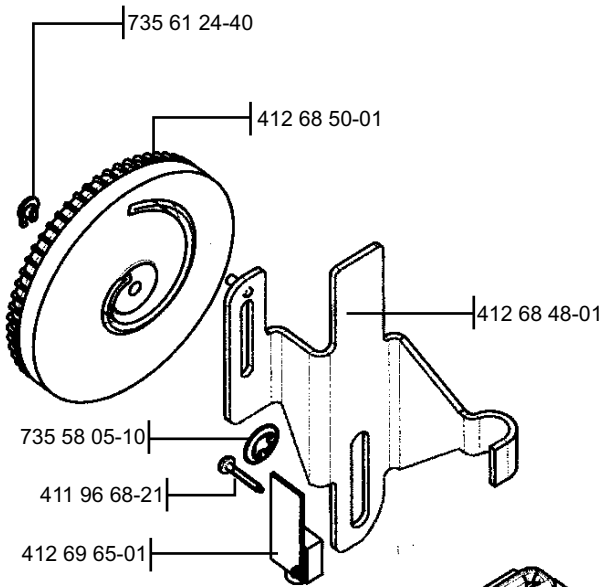
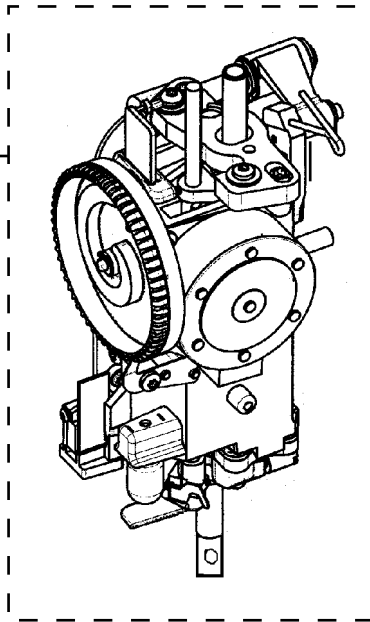

F

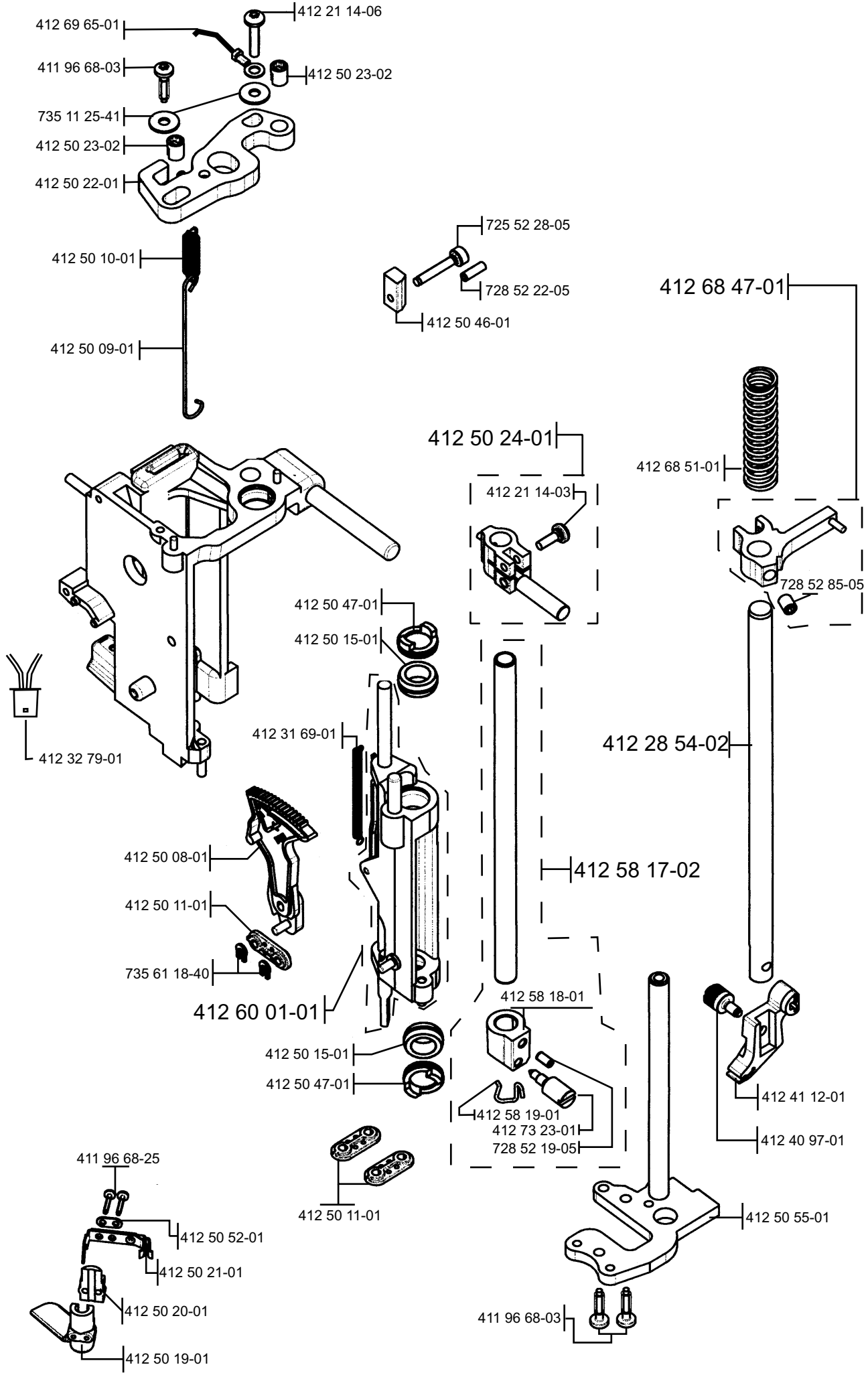



G

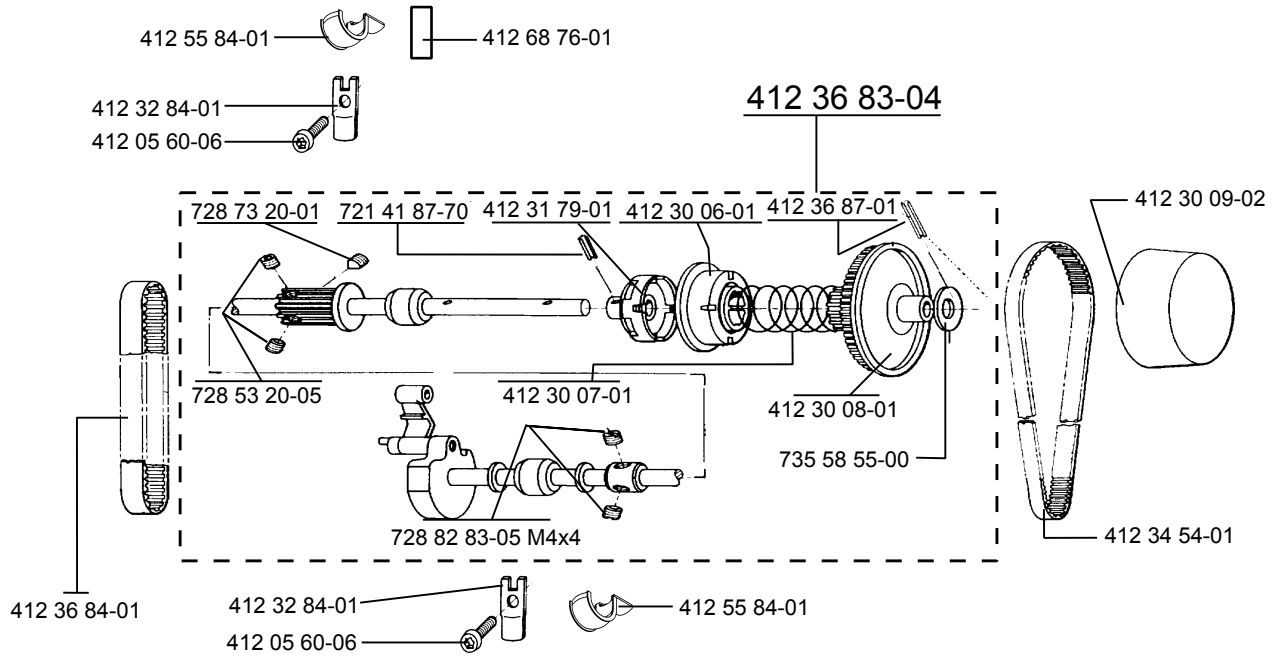

H

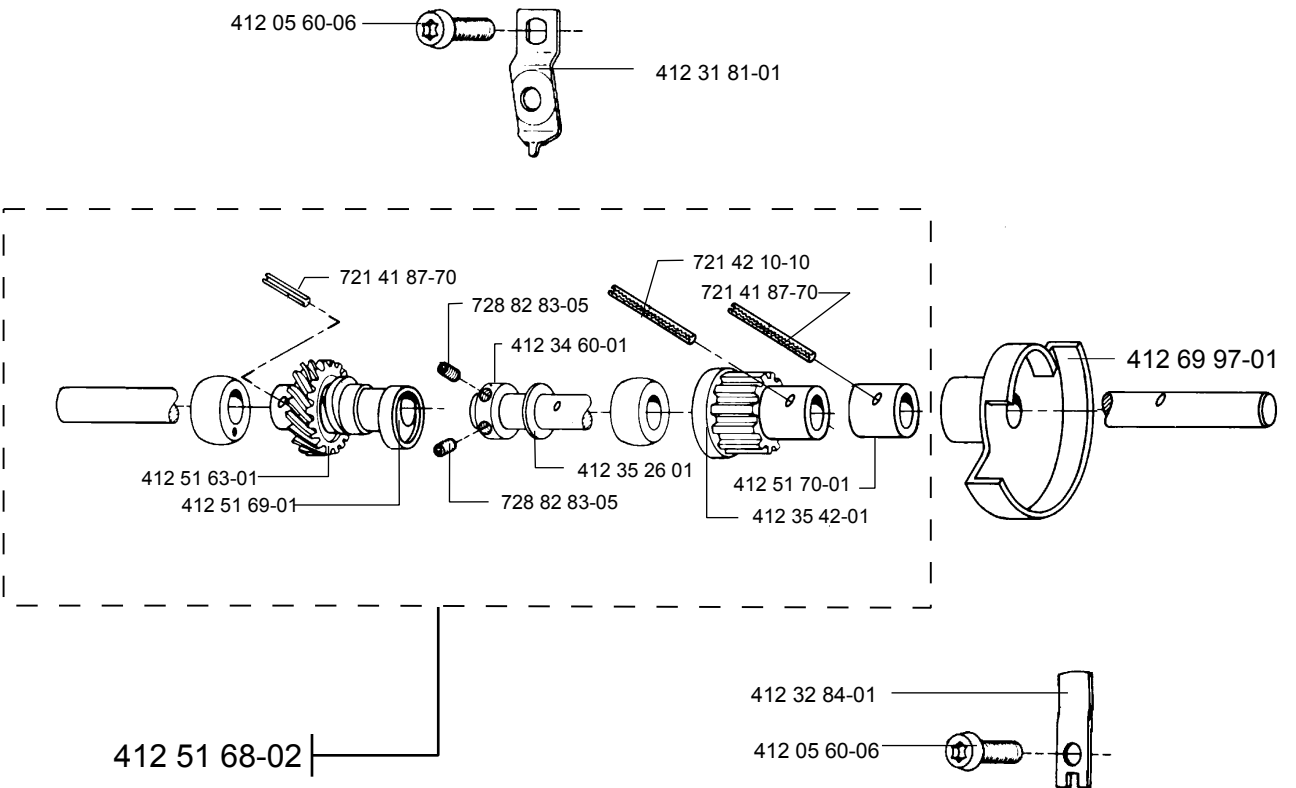

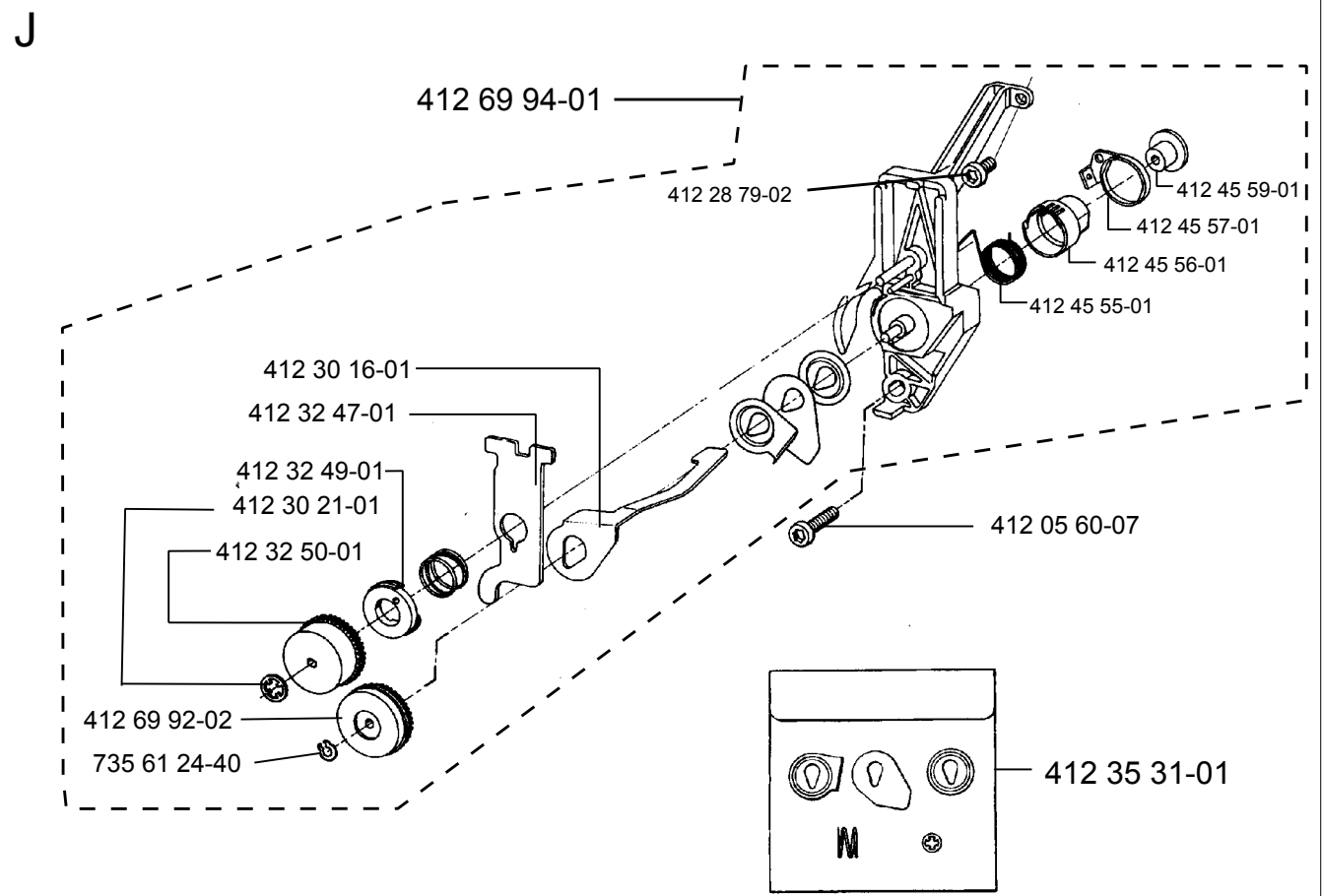
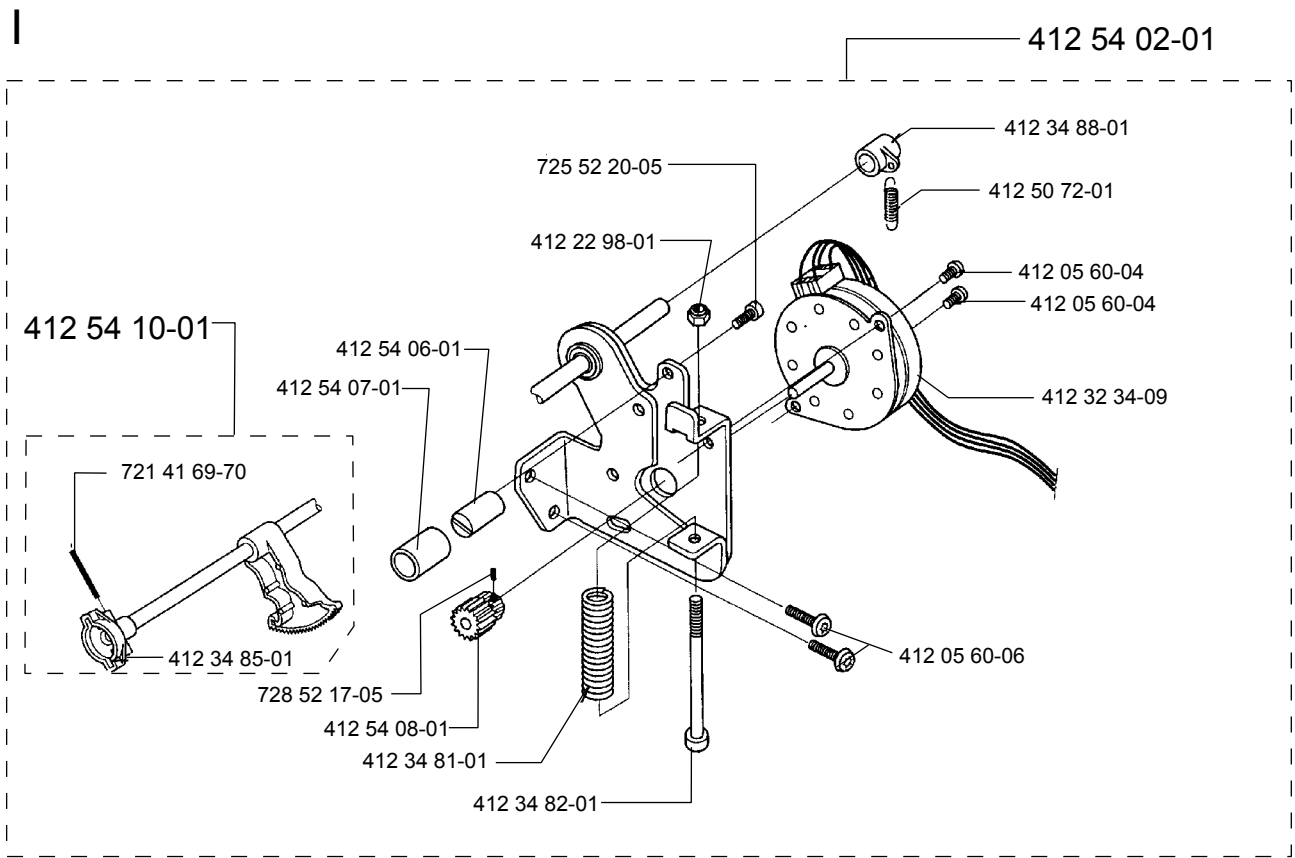

412 49 25-02

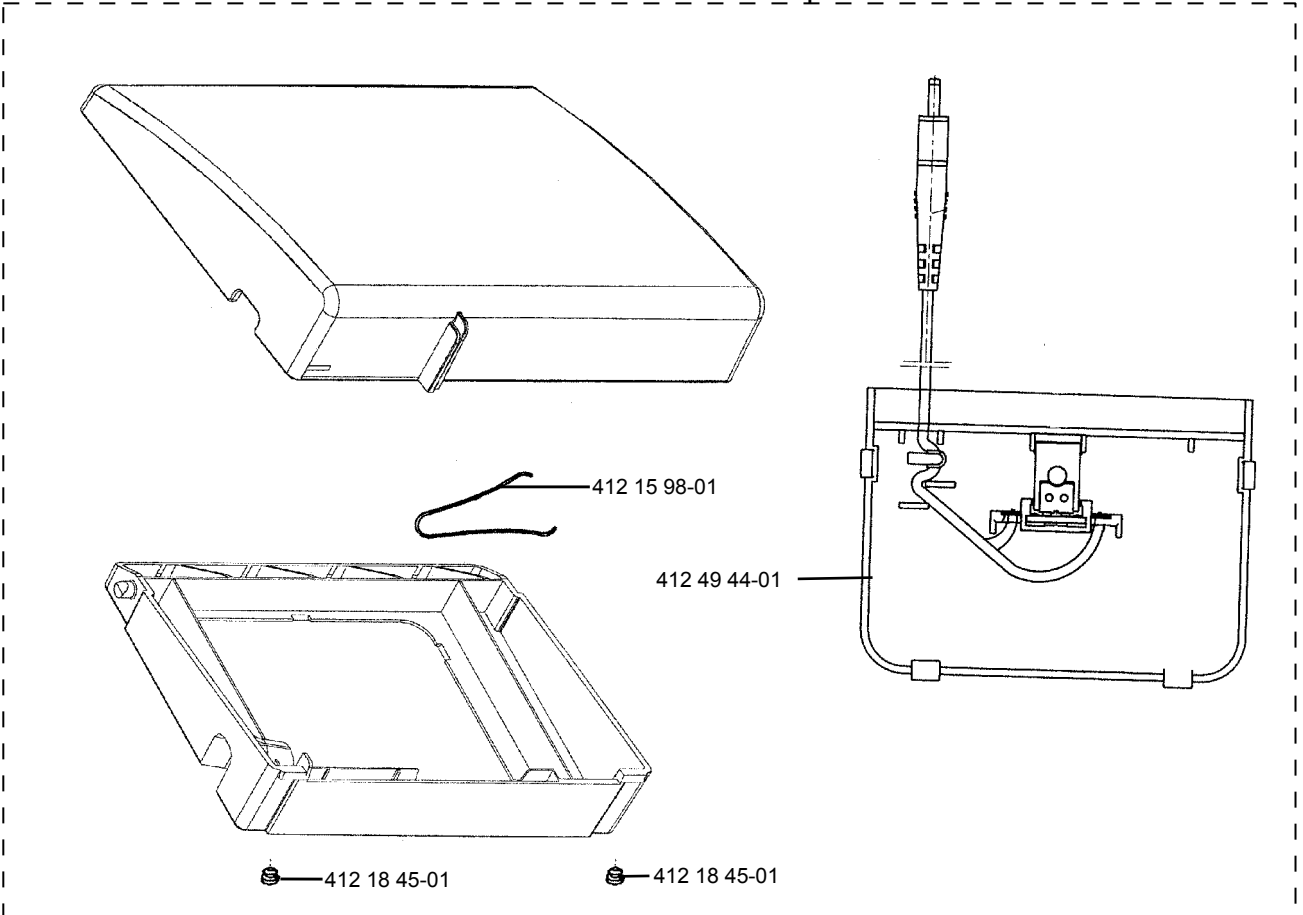

412 74 61-01

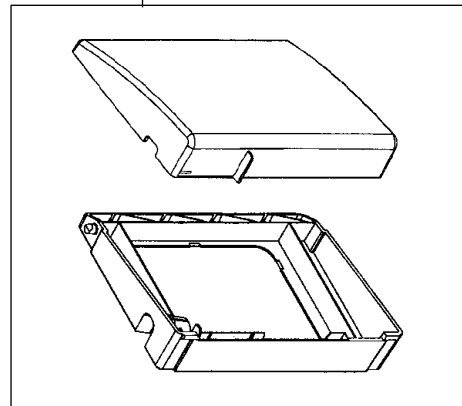

412 15 78-01  
412 15 79-03  
412 15 80-02  
412 15 81-01

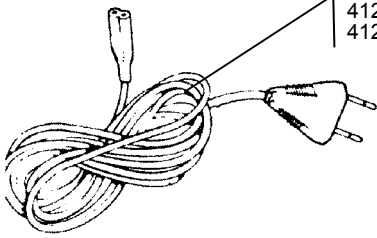

412 31 44-01  
412 31 44-02

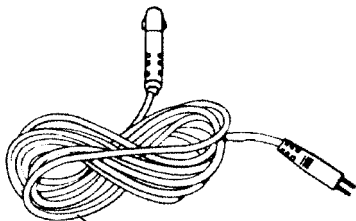

L

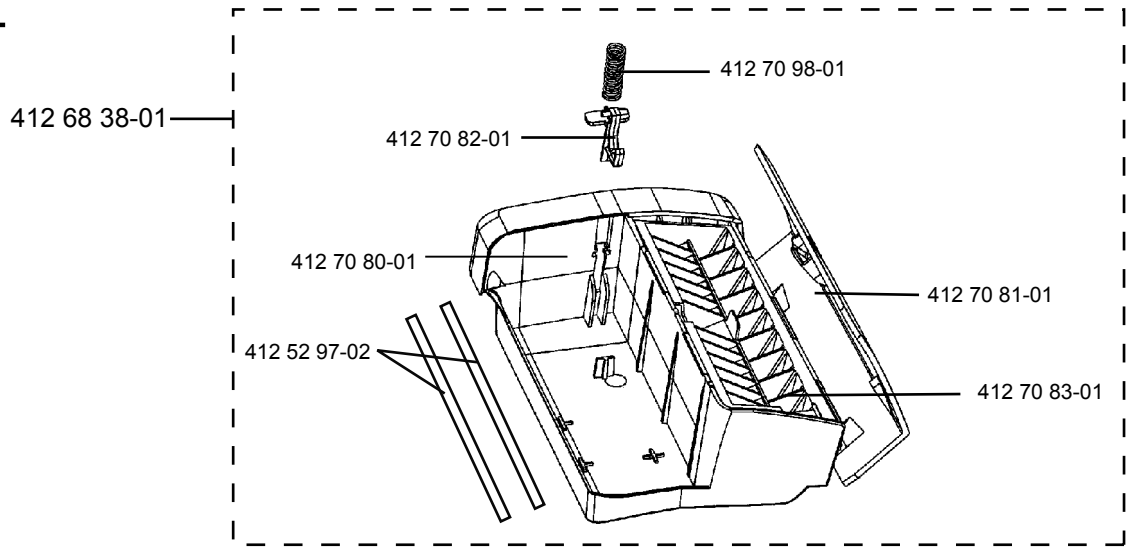

Users Guide

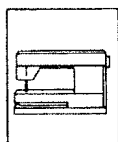

Owners handbook

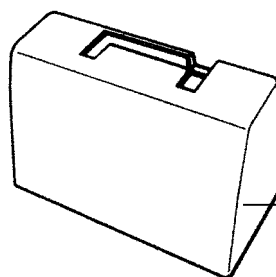
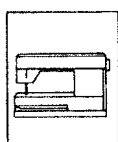

412 68 37-01 Hard cover

- 412 73 38-01 Users Guide Swe
- 412 73 38-06 Users Guide Dan
- 412 73 38-10 Users Guide Jap
- 412 73 38-11 Users Guide Fin
- 412 73 38-21 Users Guide Nor
- 412 73 38-26 Users Guide Eng
- 412 73 38-31 Users Guide Fra
- 412 73 38-36 Users Guide Holl
- 412 73 38-41 Users Guide Ita
- 412 73 38-51 Users Guide Germ
- 412 73 38-56 Users Guide Russ
- 412 73 38-82 Users Guide Pol
- 412 73 38-90 Users Guide Cz

- 412 73 39-01 Owners Handbook Swe
- 412 73 39-06 Owners Handbook Dan
- 412 73 39-10 Owners Handbook Jap
- 412 73 39-11 Owners Handbook Fin
- 412 73 39-21 Owners Handbook Nor
- 412 73 39-26 Owners Handbook Eng
- 412 73 39-31 Owners Handbook Fra
- 412 73 39-36 Owners Handbook Holl
- 412 73 39-41 Owners Handbook Ita
- 412 73 39-51 Owners Handbook Germ
- 412 73 39-56 Owners Handbook Russ
- 412 73 39-82 Owners Handbook Pol
- 412 73 39-90 Owners Handbook Cz

ACCESSORIES



412 35 31-01  
Thread tension  
set



412 39 09-25  
Plastic bag  
with access.  
Platinum 770



412 56 15-45  
Plastic bobbins  
10 pac



412 57 01-01



412 36 14-01